

CONFIDENTIAL & PROPRIETARY INFORMATION: This drawing and the information it contains is the property of BCN Technical Services, Inc. (BCN) and are being provided upon the understanding and agreement between BCN and recipient that recipient will use them only for purposes specified and approved by BCN and will not use them for any other purposes; that recipient will not disclose them in any way to any individual or entity, other than recipient's agents or employees engaged in performing the purposes specified and approved by BCN, and that recipient will immediately return this drawing, in original or copy form, to BCN upon request. Recipient's acceptance of delivery of this drawing constitutes acceptance of these terms.

OCT 17 2018

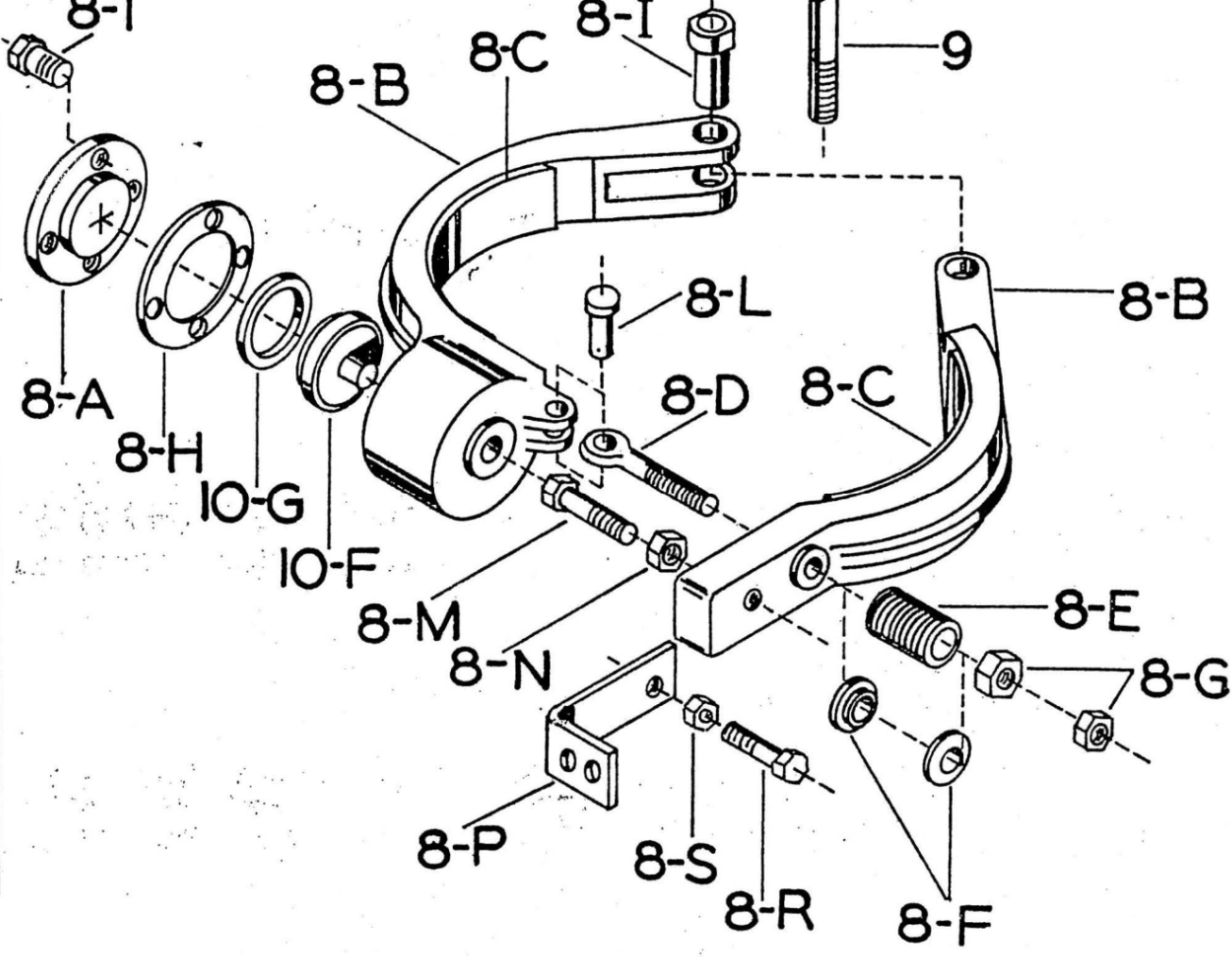

PARTS LIST

- | | |
|--|--|
| <ul style="list-style-type: none"> 8-A CYLINDER COVER 8-B BRAKE STRAP HALVES 8-C LININGS WITH RIVETS 8-D BRAKE SPRING ROD 8-E BRAKE SPRING 8-F BRAKE SPRING WASHER 8-G BRAKE ROD NUT 8-H COVER GASKET 8-L SPRING ROD PIN 8-M STOP SCREW 8-N STOP SCREW NUT * NOT SHOWN | <ul style="list-style-type: none"> 8-P BRAKE STOP BRACKET 8-R SET SCREW 8-S SET SCREW NUT 8-T COVER BOLT 8-I ECCENTRIC 9— BRAKE ANCHOR STUD 10-F PISTON 10-G PISTON PACKING 6— BRAKE COLLAR * |
|--|--|

NOTE: SEE SHEET B-2 FOR BRAKE OPERATING INSTRUCTIONS

| ORDER | THIS DRAWING IS ISSUED ONLY BY THE CONSENT OF THE OFFICERS OF THE E. W. BLISS CO., UPON REPRESENTATION THAT IT WILL BE RETAINED IN STRICT CONFIDENCE, NEITHER TO BE DUPLICATED OR EXHIBITED EXCEPT TO FACILITATE USE OR MANUFACTURE OF E. W. BLISS CO. PRODUCTS. | E. W. BLISS COMPANY—U.S.A. HEAVY EQUIPMENT DIVISION CANTON, OHIO - SALEM, OHIO - HASTINGS, MICH. | | | | | | | | | |
|--------------|--|---|---------------------------------------|--|--|-----------|--|-------|-----|------|--|
| | | BREAK ALL SHARP EDGES | <u>AIR RELEASING BRAKE PARTS LIST</u> | | | | | | | | |
| | | DR. FENWICK 8-20-65 | <u>SHEET B-1</u> | | | | | | | | |
| | <table border="1" style="width: 100%; border-collapse: collapse;"> <thead> <tr> <th style="width: 5%;">NO.</th> <th style="width: 95%;">REVISION DESCRIPTION</th> </tr> </thead> <tbody> <tr> <td> </td> <td> </td> </tr> </tbody> </table> | NO. | REVISION DESCRIPTION | | | CH. _____ | <table border="1" style="width: 100%; border-collapse: collapse;"> <tr> <td style="width: 50%;">SCALE</td> <td style="width: 50%;">1/8</td> </tr> <tr> <td>NONE</td> <td> </td> </tr> </table> | SCALE | 1/8 | NONE | |
| NO. | REVISION DESCRIPTION | | | | | | | | | | |
| | | | | | | | | | | | |
| SCALE | 1/8 | | | | | | | | | | |
| NONE | | | | | | | | | | | |
| | TOLERANCE ALLOWANCE UNLESS OTHERWISE SPECIFIED FRACTIONAL FINISH DIMENSIONS ± 1/64 DECIMAL FINISH DIMENSIONS ± .003 | | | | | | | | | | |