

# PARTS LIST

## BARREL AND CYLINDER ASSEMBLY

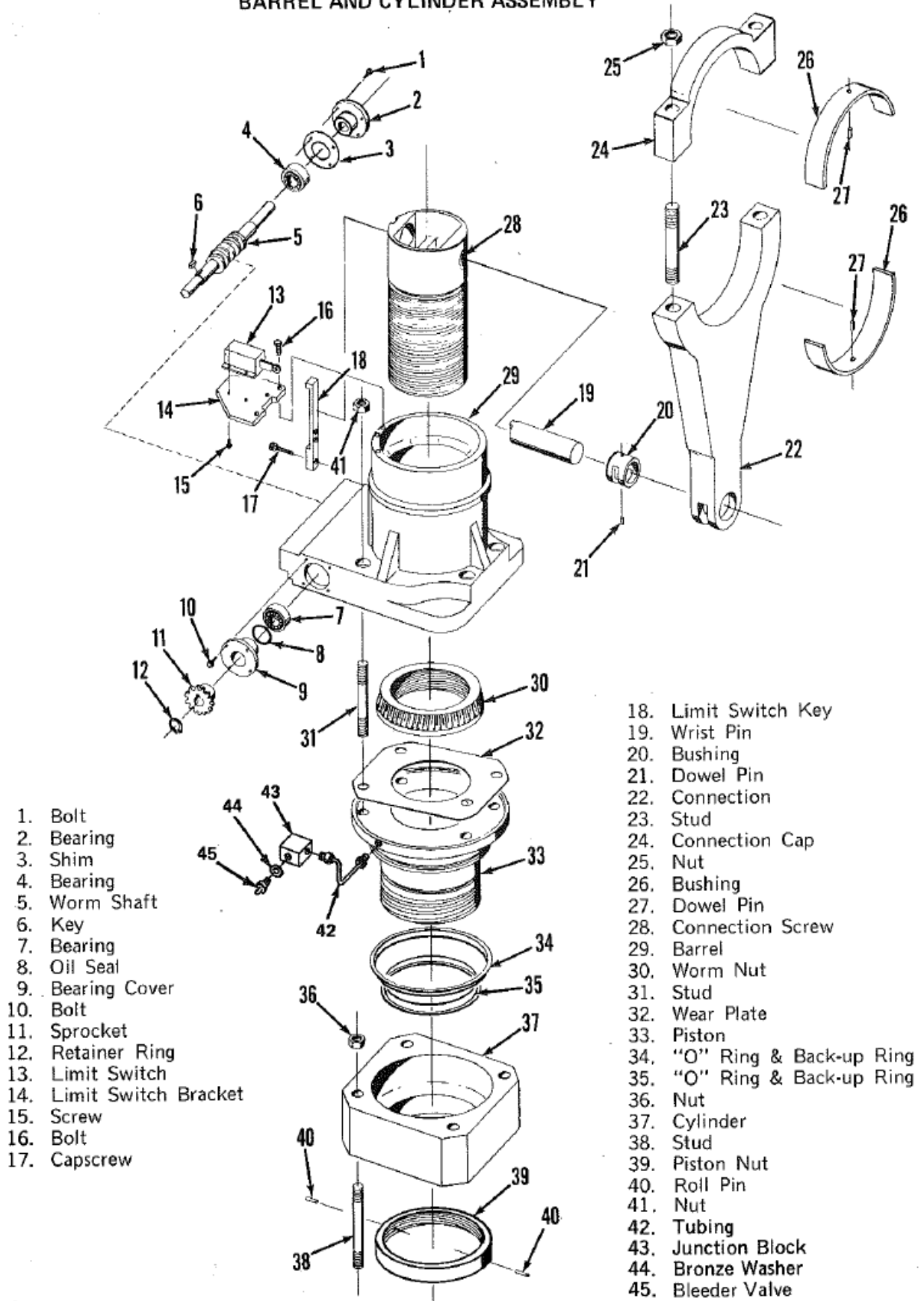

1. Bolt
2. Bearing
3. Shim
4. Bearing
5. Worm Shaft
6. Key
7. Bearing
8. Oil Seal
9. Bearing Cover
10. Bolt
11. Sprocket
12. Retainer Ring
13. Limit Switch
14. Limit Switch Bracket
15. Screw
16. Bolt
17. Capscrew

18. Limit Switch Key
19. Wrist Pin
20. Bushing
21. Dowel Pin
22. Connection
23. Stud
24. Connection Cap
25. Nut
26. Bushing
27. Dowel Pin
28. Connection Screw
29. Barrel
30. Worm Nut
31. Stud
32. Wear Plate
33. Piston
34. "O" Ring & Back-up Ring
35. "O" Ring & Back-up Ring
36. Nut
37. Cylinder
38. Stud
39. Piston Nut
40. Roll Pin
41. Nut
42. Tubing
43. Junction Block
44. Bronze Washer
45. Bleeder Valve

# OVERLOAD VALVE ASSEMBLY

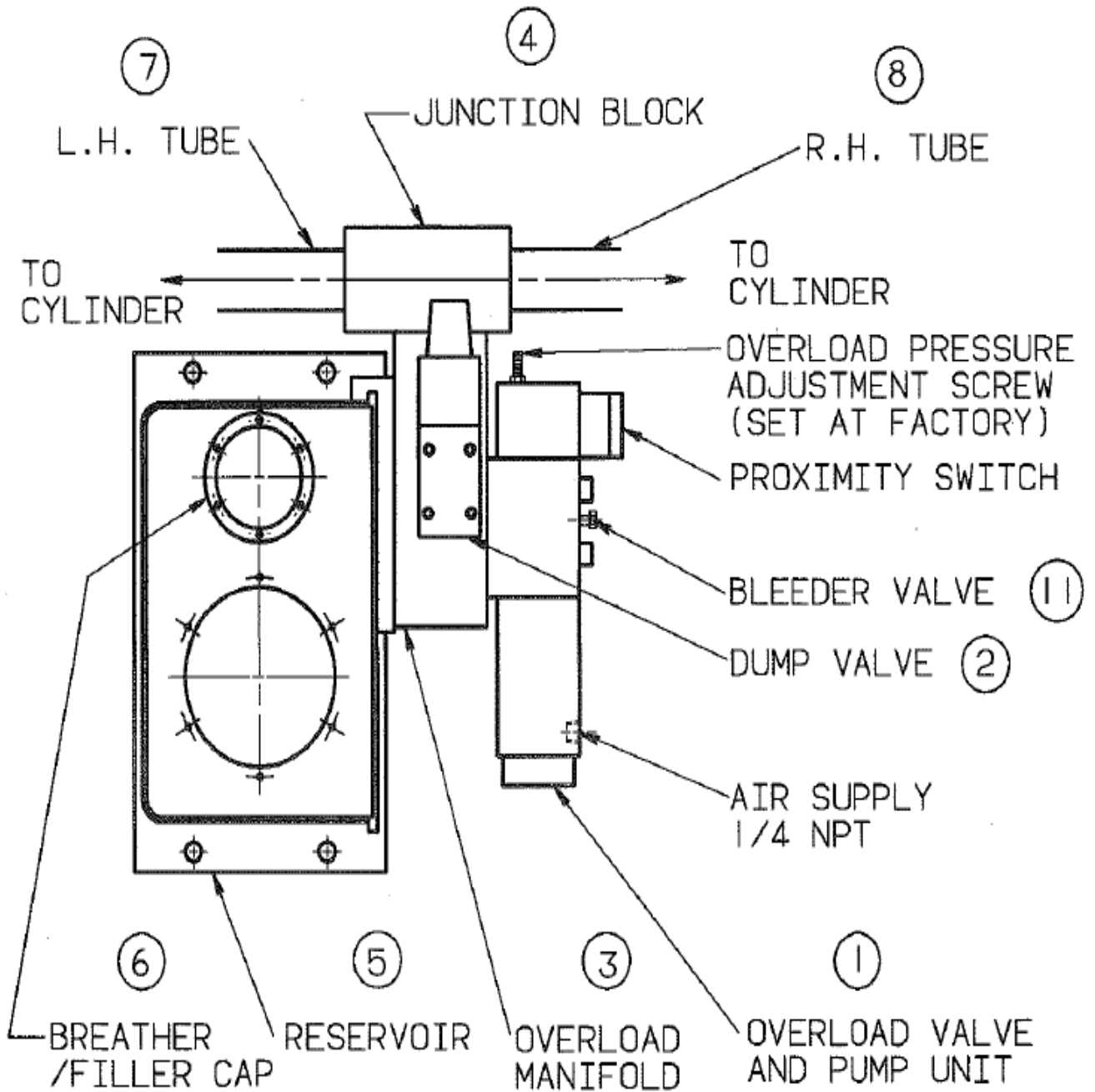

SCHEMATIC DIAGRAM

